

- FLOOR PATTERN GENERAL NOTES**
- A. FINISH TO TRANSITION IN CENTER LINE OF DOOR WAY.
 - B. PROVIDE TRANSITION STRIPS AT CARPET LOCATIONS.
 - C. USE SS TRANSITION STRIPS AT TILE LOCATIONS.
 - D. WHOLE PIECES OF TILES SHALL BE USED AS POSSIBLE.
 - E. TILE IN TOILETS SHALL SLOPE TO FLOOR DRAINS.
 - F. PATTERN LEGEND INDICATES MATERIAL ONLY; LAYOUT OF TILE TBD.

- FLOOR PATTERN KEY NOTES**
- 1. TRANSITION STRIP IS TS-1.
 - 2. TRANSITION STRIP IS TS-2.

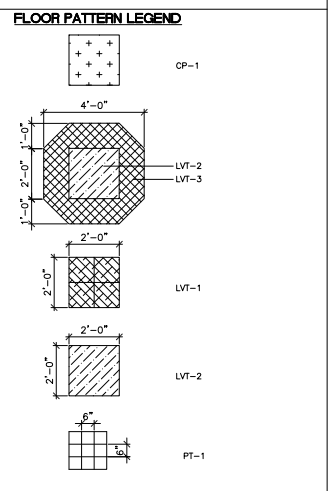

100% SUBMITTAL
 BID SET -
 CONSTRUCTION
 DOCUMENTS
 DATE: DECEMBER, 21 2012

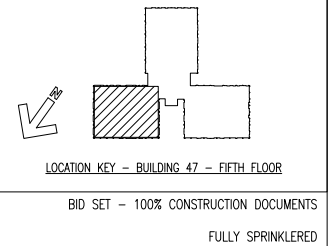

FIFTH FLOOR-WARD EAST-FLOOR PATTERNS
 SCALE: 1/4"=1'-0" 1/4"=1'-0" 1/4"=1'-0"

BY	REVISIONS	DATE

LINDBERGH & ASSOCIATES, LLC
 2170 Ashley Phosphate Road - Suite 304
 Charleston, South Carolina, 29406
 Phone: (843)553-6670 Fax: (843)553-0755



CONFIDENTIAL THESE DRAWINGS MUST BE RETURNED TO FACILITIES MANAGEMENT SERVICE, PROJECT SECTION, UPON COMPLETION, OR FINAL USE BY THE CONTRACTOR FOR BIDDING PURPOSES.

ASBESTOS WARNING: ASBESTOS CONTAINING BUILDING MATERIALS (ACBM) ARE PRESENT THROUGHOUT THE FACILITY. IF CONTRACTORS FIND ACBM, OR SUSPECT FINDING ACBM, THEY SHALL IMMEDIATELY STOP WORK AND CONTACT THE PROJECT COR.

SCALING NOTES: FULL SIZE V.A. "T" SHEETS (SCALE AS INDICATED) AND HALF SIZE V.A. "D" SHEETS (@ THE SCALE INDICATED LETTER SIZE DRAWINGS ARE NOT TO SCALE.

GENERAL NOTE: CONTRACTORS AND ARCHITECT/ENGINEERING FIRMS ARE RESPONSIBLE FOR THE FIELD VERIFICATION OF ALL EXISTING CONDITIONS.

Project Title
**RENOVATE
 WARD 5 EAST**

Drawing Title	Date	
FIFTH FLOOR - WARD EAST	12/21/12	
FLOOR PATTERNS		
Building Number	Checked	Drawn
47	JSA	NEK
Location	ASHEVILLE, NC	
Drawing No.	1-102	
Dwg	40 of 78	

